

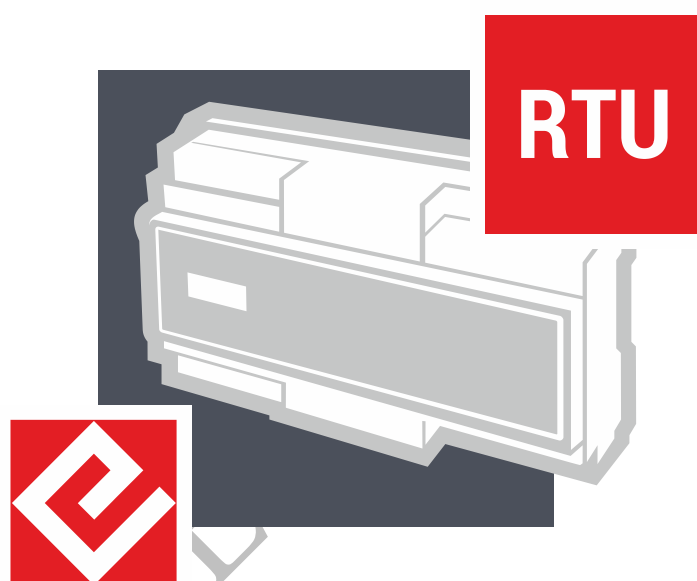

User Guide to Vdip2 system SW



T A
Č R

Tento projekt je spolufinancován se státní podporou Technologické agentury ČR v rámci Programu THETA.

www.tacr.cz

Výzkum užitečný pro společnost.

Project number: TK04020187

Project name: Development of a system for locating faults Vdip of the 2nd generation



MACHINE TRANSLATED



CONTENT

1. Introduction	4
2. Fault localization with the Vdip system	4
2.1. Technical description	4
3. Vdip2 System User Interface	5
3.1. Fault event list.....	6
3.2. Fault event browser	9
3.3. Grouping of fault events – Fault Group	12
3.3.1. Fault Group basic information	13
3.3.2. Fault Group detail information	14
3.4. Network map icon description	15
4. VQI Module User Interface	16
4.1. VQI module main card	17
4.1.1. Setting	18
4.1.2. Detail Settings	19
4.2. Retrieve VQI data	21
4.2.1. Tables and graphs with VQI results	21
4.2.2. VQI map base	23



1. INTRODUCTION

This manual describes the user interface of the Vdip2 fault localization system SW package and the VQI voltage quality index presentation module, which are designed for monitoring the high-voltage distribution system. This system and its SW superstructure were developed with the financial support of the TAČR TK04020187 project - Development of the Vdip 2nd generation fault localization system (Vdip2). The Vdip2 SW package integrates functions for localization of fault conditions, which are protected by the European patent EP2940483 and the national patent 305209.

2. FAULT LOCALIZATION WITH THE VDIP SYSTEM

The Vdip system for locating unsymmetric faults (Vdip system) is a unique system designed for autonomous fault localization in high-voltage (HV) systems. It is in these systems, which are predominantly operated as compensated, that finding the fault is very problematic and time-consuming, and due to the absence of suitable technical solutions, it leads in the vast majority to the multiple switching of the affected outlet into failure. Long-term search for a fault and its re-ignition significantly increases the risk of fatal injury due to step and touch voltages, this risk is further increased by the proximity of the HV system to areas with high population penetration and the high vastness/complexity of HV systems. The presented result has been systematically developed to enable automatic localization of these faults immediately after their occurrence, without the need to re-switch the lines to the fault and extend the time of passage of the fault current, which significantly contributes to reducing the probability of electric shock to persons, killing of animals and the occurrence of high damage to property (fire) due to the passage of fault current.

2.1. TECHNICAL DESCRIPTION

The concept of the Vdip system is simplified on the example of the outlet of the compensated distribution system in Fig. 1-1. The monitoring system itself consists of outlet protections (FPs), which transmit the fault record from the power supply substation to the Central Unit along the L2 communication route, and distributed voltage monitoring units (DMUs), which are located on the secondary sides of the distribution transformers (MV/LV). These DMUs, on the instruction of the Central Unit, transmit the fault records for the specified fault time (given by the outlet protection) to the central unit along the L3 communication route, where they are analyzed together with the fault records from the outlet protection and the necessary changes in the return component of current and voltage for the Vdip algorithm are performed. Based on these changes, one specific fault location is determined in the network model. One fault record of the outlet protection may contain several changes sufficient to localise the fault, in these cases the localisation is carried out according to the number of these events and as a result, the most trustworthy of them is selected according to the implemented rules. The results of localization on the network model can then be transferred to any system using GPS coordinates or identification in the network model (affected line, line node and distance of the fault on the given line from this node). The principle of the Vdip localization algorithm is described in detail in [1][2].



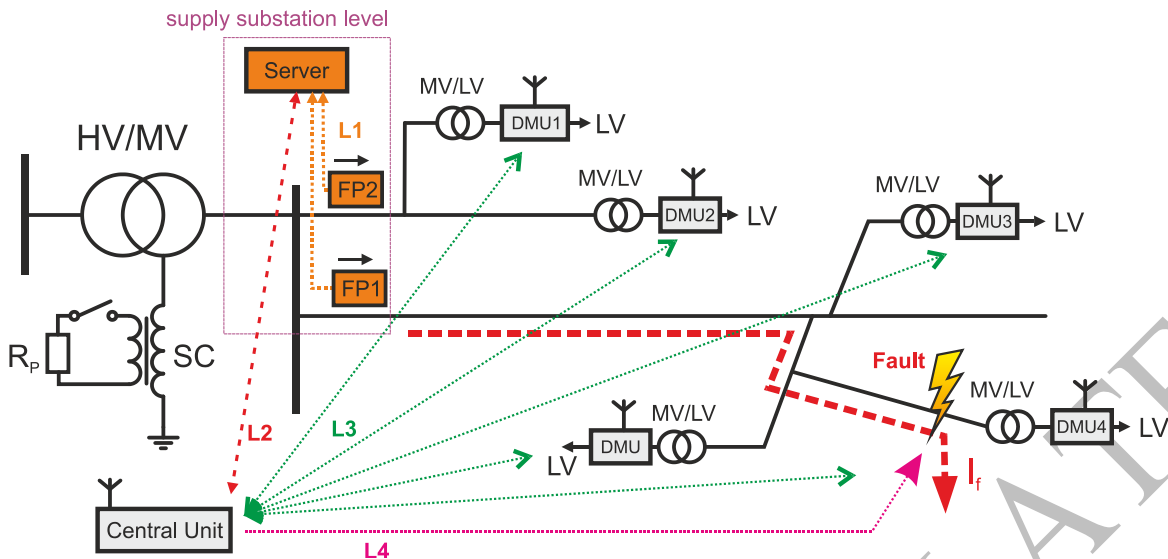

Giant. 1: The concept of the Vdip system

- [1] TOPOLÁNEK, D.; LEHTONEN, M.; TOMAN, P.; ORSÁGOVÁ, J.; DRÁPELA, J. An earth fault location method based on negative sequence voltage changes at low voltage side of distribution transformers. INTERNATIONAL JOURNAL OF ELECTRICAL POWER & ENERGY SYSTEMS, 2020, vol. 118, no. 118, pp. 1-8. ISSN: 0142-0615.
- [2] TOPOLÁNEK, D.; DRÁPELA, J.; TOMAN, P.; JURAK, V.; JURIK, M.; JIRICKA, J. Evaluation of the new method Vdip for an earth fault location. CIRED - Open Access Proceedings Journal. CIRED, International Conference and Exhibition on Electricity Distribution. 2019. Madrid: AIM, 2019. pp. 1-5. ISBN: 978-2-9602415-0-1. ISSN: 2032-9644.

3. VDIP2 SYSTEM USER INTERFACE

The user logs in to the application using the assigned login and password. Based on the assigned login, the user is also assigned the following permissions:

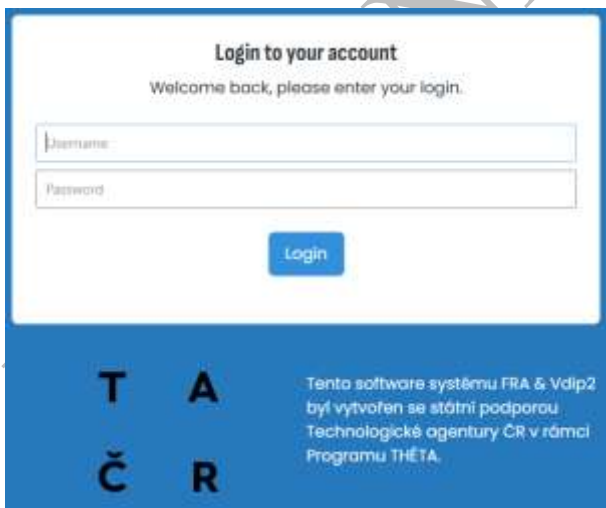

After logging in to the user interface, the main navigation bar is on the left. On this panel, you can switch between three basic tabs:

- List (Fault event list) – a list of events with parameters

- Browser (Event Browser) – viewing events with localization on the map
- Statistics – statistical evaluation of failures

The tabs allow you to click through to individual UI modules for different views of recorded and evaluated fault events. A description of the individual tabs and how to navigate them is presented below.

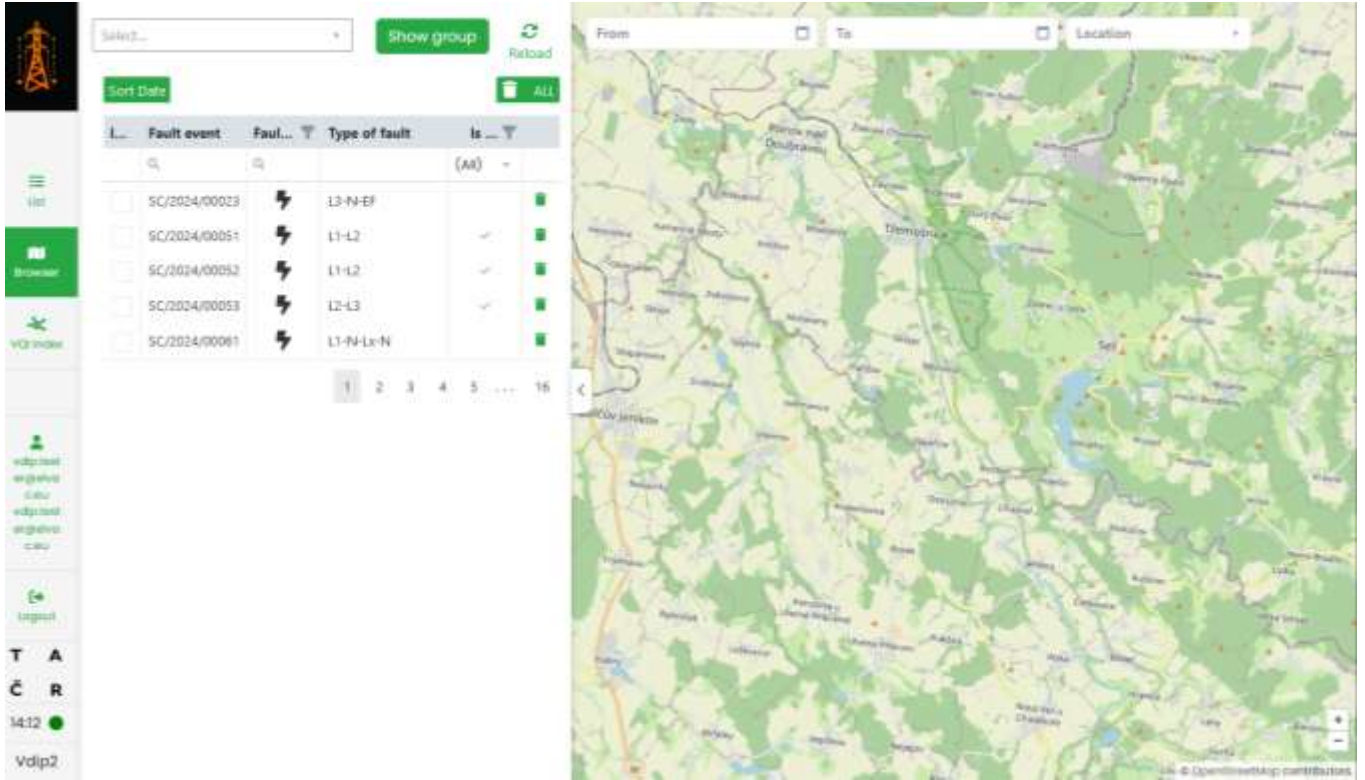

3.1. FAULT EVENT LIST

The *Fault event list (List)* tab allows you to display a list of all fault events with assigned parameters. Individual events are introduced as table rows, and the selected parameters represent table columns. In the table, individual events can be filtered and sorted by the selected column.

The screenshot shows the 'Fault event list' tab with a table containing the following data:

Is authorized	Name	Start date	End date	Fault group	Fault type	Type of fault	State	Description	Code
✓	SC/2024/00133	17.12.2024 09:38:52.973	17.12.2024 09:44:22.973	FG/2024/00113	ShortCircuit		FailEventTimeOut		20241217093852973
✓	SC/2024/00132	11.12.2024 05:04:15.468	11.12.2024 05:04:15.485	FG/2024/00113	ShortCircuit	L1-L2	SuccessfullyCalculated...		20241211050415468
✓	SC/2024/00131	7.12.2024 10:29:50.355	7.12.2024 10:34:50.355	FG/2024/00110	ShortCircuit		FaultAnalysisTimeOut		20241207102950355
✓	SC/2024/00130	7.12.2024 10:26:31.738	7.12.2024 10:31:31.738	FG/2024/00110	ShortCircuit		FaultAnalysisTimeOut		20241207102631738
✓	SC/2024/00129	7.12.2024 10:26:00.771	7.12.2024 10:31:00.771	FG/2024/00110	ShortCircuit		FaultAnalysisTimeOut		20241207102600771
✓	SC/2024/00128	7.12.2024 10:19:41.645	7.12.2024 10:19:41.673	FG/2024/00101	ShortCircuit	L2-L3	SuccessfullyCalculated...		20241207101941645

The displayed parameter fields in the table are:

- Is authorized

Identification of the Fault Event Authorisation Status *Is Authorized* – The Fault Group to which the Fault Event belongs has been authorised by an authorised employee (such closed events/groups contain a completed fault location and can no longer be modified)

- Name
Name of the fault, name is composed according to the key TP/yyyy/nnnnn, where TP is the type of fault: EF = ground fault/ SC = short circuit
yyyy is the year in which the failure occurred
nnnnn is the event identification number
- Start date
Date and time of occurrence of the event – corresponds to the start time of the Data Segment (DS) in which the given failure is located, the data segment represents the semi-steady state of the given failure record (see **Chyba! Nenalezen zdroj odkazů.**)
- End date
Date and time of the end of the event – corresponds to the end time of the Data Segment (DS) in which the given failure is located, the data segment represents the semi-steady state of the given failure record (see **Chyba! Nenalezen zdroj odkazů.**)
- Fault group
The event group to which the event was assigned. Each fault event is assigned one default Fault Group (FG). In the event that there are multiple fault events in the fault record, these events are automatically assigned to one FG. A group of events is subject to the following markings: FG/yyyy/nnnnn, where yyyy is the year in which the failure occurred
nnnnn is the identification number of the group
- Fault type
The type of disorder has two values:
EarthFault Ground Connection
ShortCircuit – Short Circuit
- Type of fault
Type of disorder with respect to the phases affected. The marking captures which phases (L1, L2, L3) were affected by the failure, or whether there was also a connection with the ground (N). An overview of the options is given in the table:

Table 1: Type of fault options

Type of fault	Description
L1-N-EF, L2-N-EF, L3-N-EF	Ground connection in phase L1, L2, L3
L2-N-L3-N, L1-N-L3-N, L1-N-L2-N	Double earth connection (two non-congruent earth connections) on one HV outlet
L1-N-Lx-N, L2-N-Lx-N, L3-N-Lx-N	Double earth connection (two non-concurrent earth connections) one ground connection is



	located on the given outlet in the L1, L2, L3 phase and the other on another HV outlet (Lx)
L1-N, L2-N, L3-N	Single-phase short circuit in phase L1, L2, L3
L1-L2, L2-L3, L1-L3	Two-phase short circuit between phases L1-L2, L2-L3, L1-L3
L1-L2-N, L2-L3-N, L1-L3-N	Two-phase ground fault between conductors L1-L2-N, L2-L3-N, L1-L3-N
L1-L2-L3	Three-phase short circuit
L1-L2-L3-N	Three-phase ground fault

- **State**

The evaluation status of the FRA processing event, the possible statuses that can be displayed in the user interface, are listed in the following table:

State	Description
SuccessfullyCalculated	Successful evaluation of the event
SuccessfullyCalculatedWithAlert	A successful evaluation of an alert event
SuccessfullyCalculatedEmpty	A successful evaluation of the event took place, but the location of the fault location was not determined.
AnalysisFailed	The calculation ended in error.
AnalysisTimeOut	The calculation took too long.
FaultAnalysisInProgress	Analysis of the received fault signal is in progress
FaultEventTimeOut	The calculation took too long, Comtrade was not delivered.
ComtradeGetFile	Request Comtrade file, waiting for delivery.
AnalysisInProgressVDIPSmelc	A calculation is in progress.

- **Description** – additional information from the calculation process
- **Start date** – numeric identifier of the derivation from the start time of the event



- ... (more options)

- Show event detail

Clicking on the event detail (more description below *Fault event detail info*)

- Show group (map)

Clicking on the Browser tab with a pre-selected given group of events – displaying the group in the map and its parameters.

- Show event (map)

Clicking on the Browser tab with a pre-selected event – displaying the event in the map and its parameters.

- Delete

Option to delete event.

3.2. FAULT EVENT BROWSER

At the top of the module there is a drop-down menu with the choice of a group of events that the user wants to browse and display on the map. After selecting and pressing the *Show group button*, the map will display the designated location of the fault – event groups and at the same time display a group table including the listed events.

Reload button updates the list of events

The *Sort date button* sorts events by date and time of occurrence

The *Delete all button* allows you to delete all events from the list loaded into the UI

The icon  allows you to delete one fault record from the event list.

The generated table of events assigned to a group allows you to view the details of individual events, delete events from the group (delete event records). The table allows filtering or sorting according to individual parameters. The event parameters in each column are:

- Included

Indicate whether an event belongs to a selected group

- Fault event

Event identifier

- Fault type

Fault type: ground fault/short circuit – distinguished by an icon



Ground

Connection



short

circuit

- Type of fault

Event type relative to affected phases (see Table 1)

- Is authorized

Identification of the Fault Event Authorisation Status *Is Authorized* – The Fault Group to which the Fault Event belongs has been authorised by an authorised worker (events/groups closed in this way contain a completed fault location and can no longer be modified).





FG/2024/00087 Show group Reload

Sort Date ALL

I...	Fault event	Faul...	Type of fault	Is ...	
<input type="checkbox"/>	EF/2024/00105	⚠	L3-N-EF	<input type="checkbox"/>	🗑
<input type="checkbox"/>	EF/2024/00106	⚠	L3-N-EF	<input type="checkbox"/>	🗑
<input type="checkbox"/>	EF/2024/00107	⚠	L3-N-EF	<input type="checkbox"/>	🗑
<input checked="" type="checkbox"/>	EF/2024/00108	⚠	L3-N-EF	<input checked="" type="checkbox"/>	🗑
<input type="checkbox"/>	EF/2024/00109	⚠	L3-N-EF	<input type="checkbox"/>	🗑

1

By selecting a fault event in the **Browser** tab, a panel with its description will be displayed. The panel header lists its numeric code and the event type flag – SC short  circuit or EF ground fault.  The numeric code of the fault event represents the year in which the event was recorded and the forward slash of the order of the event in that year.

The description of the fault event is made through the basic data (items) on the event homepage.

 EF/2024/00108 event

Type of fault	EarthFault L3-N-EF
Start time of fault	8.12.2024 05:46:50.622
Fault duration	4.258 s
Faulty Feeder	SUM22-07-VN2B
Distance from start node	0.38 km
Faulted element	1008354104
Fault location GPS	17.938848, 49.071 
Reactance to the fault	1.82 Ω
Distance to the fault location	5.05 km
Date code	20241208054650622
State	SuccessfullyCalculate

The meaning of the information in each item is given in Table 2.

Table 2 Basic and detailed information about a fault event

Název informace		Popis - význam informace		Pozn.
anglicky	česky	pro události typu zkrat (SC)	pro události typu zemní spojení (EF)	
Type of fault	Typ poruchy	udává typ zkratu - jednofázový (L1-N, L2-N, L3-N), dvoufázový (L1-L2, L2-L3, L1-L3), dvoufázový zemní (L1-L2-N, L2-L3-N, L1-L3-N), třífázový (L1-L2-L3), nebo třífázový zemní (L1-L2-L3-N), dvojitě ZS na stejném vývodu (L2-N-L3-N, L1-N-L3-N, L1-N-L2-N), dvojitě ZS na různých vývodech (L1-N-Lx-N, L2-N-Lx-N, L3-N-Lx-N)	udává typ jednochuhého zemního spojení (ZS) - L1-N-EF, L2-N-EF, L3-N-EF	
Start time of fault	Začátek poruchy	odpovídá času začátku Data Segmentu (DS), ve kterém se nachází daná porucha		viz položka DS name
Fault duration	Doba trvání poruchy	celková doba trvání zkratu určená jako časový interval mezi počátkem (Start time of fault) a koncem poruchy (End time of fault)		
Faulty Feeder	Postižený vývod	identifikace vývodu, ve kterém byla porucha detekována vývodovou ochranou		
Fault location GPS	Místo poruchy	geografické souřadnice místa poruchy v geopodkladu - podbarvení okna signalizuje úroveň věrohodnosti údaje (zelená=důvěryhodný výsledek lokalizace, červená= nedůvěryhodný výsledek lokalizace), odpovídají černě zobrazenému bodu v úseku vedení v poruše v mapovém podkladu		
Distance from start node	Vzdálenost poruchy od počátečního uzlu	délka vedení mezi počátečním uzlem úseku vedení v poruše a místem poruchy		Tyto položky jsou pouze v detailním popisu poruchové události, v úvodním panelu jsou dostupné přímo z mapového podkladu -
Faulted element	Úsek vedení v poruše	identifikátor úseku vedení, na kterém byla porucha lokalizována - odpovídá červeně zobrazenému úseku v mapovém podkladu		
Reactance to the fault	Reaktance do poruchy	podélná reaktance vedení mezi napájecí rozvodnou a místem poruchy v ohmech		
Distance to the fault location	Vzdálenost do poruchy	délka vedení mezi napájecí rozvodnou a místem poruchy		
Date code	Časový kód	časový kód poruchy je čas začátku poruchy zapsaný bez oddělovacích znaků		
State	Stav	uvádí výsledek výpočetního algoritmu pro lokalizaci - SuccessfullyCalculated (úspěšně vypočteno), SuccessfullyCalculatedWithAlert (úspěšně vypočteno s výstrahou), AnalysisFailed (analýza selhala)		

Information about the failure event is further supplemented on the home page by displaying it in an interactive map base, where it is possible to identify individual elements of the distribution network in the vicinity of the failure – see Figure 1.

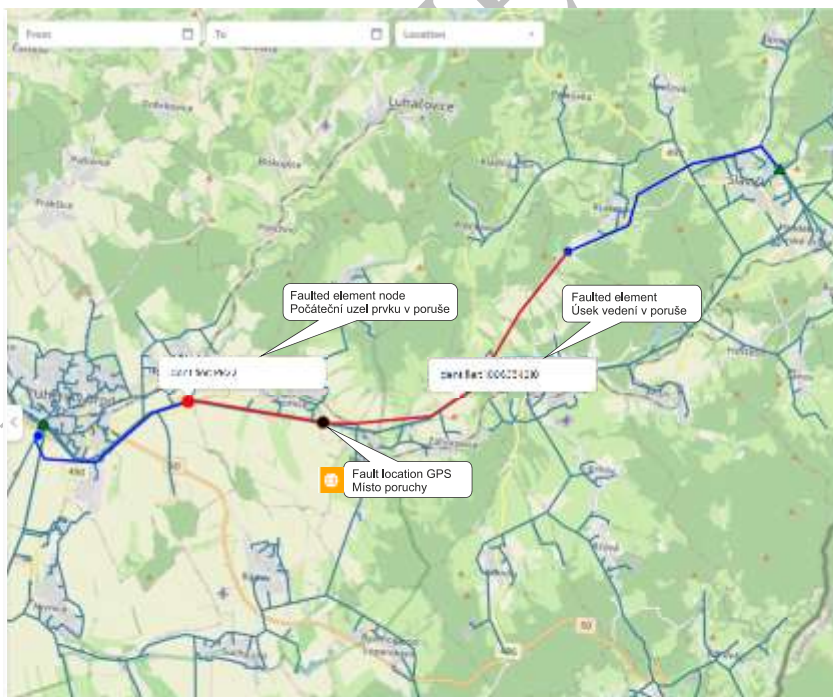

Figure 1 Description of the failure in the map



3.3. GROUPING OF FAULT EVENTS – FAULT GROUP

In addition to unique identifiers, each failure event is also assigned the designation of the FG (Fault Group). If we change the assigned designation of the fault group to one common fault group for selected faults, we can merge fault events that are locally and temporally identical and for which we assume that they have arisen from the same cause – faults on the same element of the system. By evaluating a group of faults, it is possible to increase the accuracy of localization and get closer to the actual cause of the fault. Also, the grouping of failures can be used for a detailed description of the given failure events and a detailed analysis of their cause and manifestations.

To search for fault events suitable for grouping, you can use the filters of the map base with the display of fault events and filter out faults in the selected outlet (Location) and time interval (From – To).

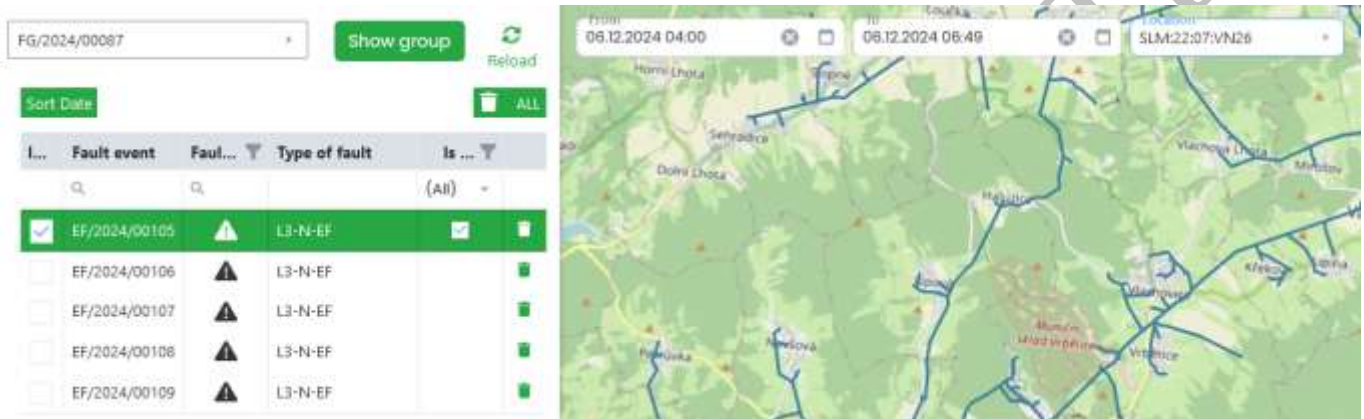

This step selects fault events that occurred on the selected outlet within the defined time range – they can have the same cause and can be analyzed with possible grouping.

If the above events have the same cause, those that are similar in place and time can be added to the selected (yellow, see the figure above) failure events by marking the Included box in the first column of the table. The procedure is illustrated in Figure 2, where the fault event EF/2024/00105 of the FG/2024/00087 group EF/2024/00106 is added.

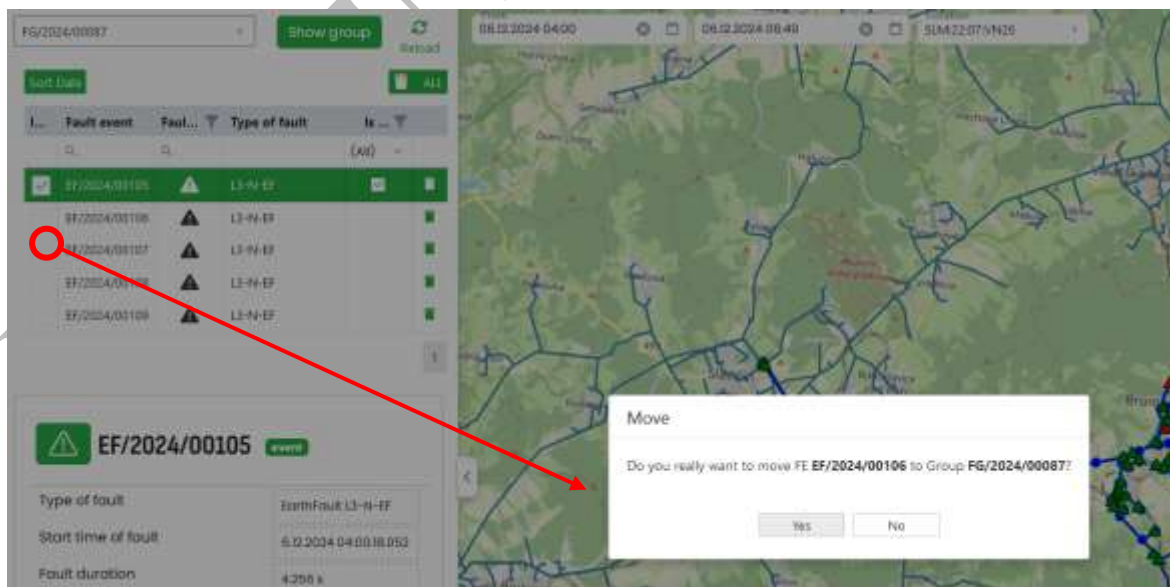

Figure 2 Add a fault event to a group



The created group of failure events can now be displayed using the Show group button (displays the detail of the selected group) in the map and with basic information in its description – see Figure 3. The map base displays all localized failure events included in the group and listed in the list of failure events. By applying the Show group button, the filters are automatically set so that the table contains all events in the group. The filters of the map base correspond to the location (affected outlet) and the time range from the beginning of the first failure event in the group to the end of the last one in the group. By extending the time of the filter set in this way, it is possible to supplement the table of events with other possible relevant failures (e.g. in a situation where the fault search has not yet been completed). Note: Since each failure event has a unique failure group number (FG) preset, the group can also consist of a single failure event. It can then be worked with in the same way as with a group of multiple failure events!

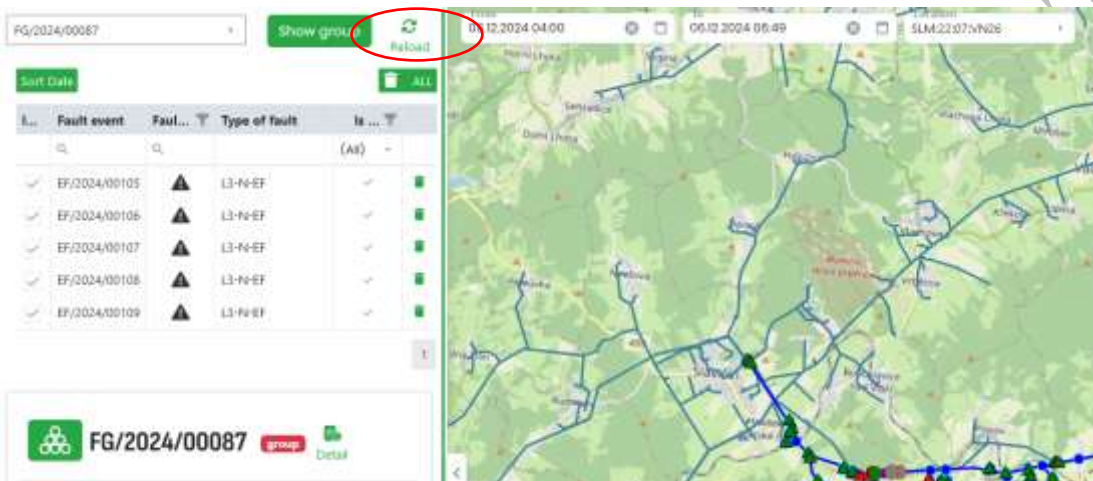

Figure 3 Group view

3.3.1. FAULT GROUP BASIC INFORMATION

The description of a group of fault events is based on the same items (Table 2), as a description of one failure event and also its display in the map base, corresponds to the display of individual failure events. However, when describing and displaying a group, the meaning of some items or the color marking of position indicators in the map background changes:

1. Type of fault – is determined as the intersection of types of failures in a group, based on what types of failures each failure event is. If the fault type matches all events, the type is filled in. If there is a match to at least the fault character of the Earth Fault/Short Circuit, EarthFault/ShortCircuit is filled in here. If the fault events are of different types, the result is the description CombinedFault.
2. The start time of fault is the beginning of the first failure in the group
3. The end time of fault is the end of the last failure in the group
4. The location of the failure (Fault location GPS) is the place of the so-called priority localization, i.e. the result of the localization of the fault event in the group that has been evaluated as trustworthy (unambiguous) – this failure event is marked in the list of fault events included in the group with a red symbol of the type of failure – see Figure 4. The results of localization in the remaining failure events are colored gray in the map and their coordinates are not stated in the group description.



Note: A failure event of a given group is marked as a priority localization, The parameters of this priority event of the group are copied into the detailed information of the given FG. The event (FE) with the greatest distance from the power substation that has a valid localization (GPS field is colored green) is marked as priority, if none of the events has a valid localization, then the white coloration is preferred (it is not possible to decide on the plausibility) and the last red coloration (untrusted localization) – information about the plausibility of the localization is also copied into the FG field:

Fault location GPS 17.730210, 49.036

- The basic description of the group contains the Exact Location item, in which there is a button for adding the actual location of the failure to the map base **Select Location**. With this button, a moving point is inserted into the map, which can be placed according to the known position of the actual fault. After its placement, it is colored green and its position determines the value in the Fault location distance error item – see Figure 4.
- Button **Detail** located in the header of the Failure Group Basic Information Panel (Figure 4) will also display a panel of detailed information, where it is possible to add other facts found at the actual location of the failure – see the next chapter.

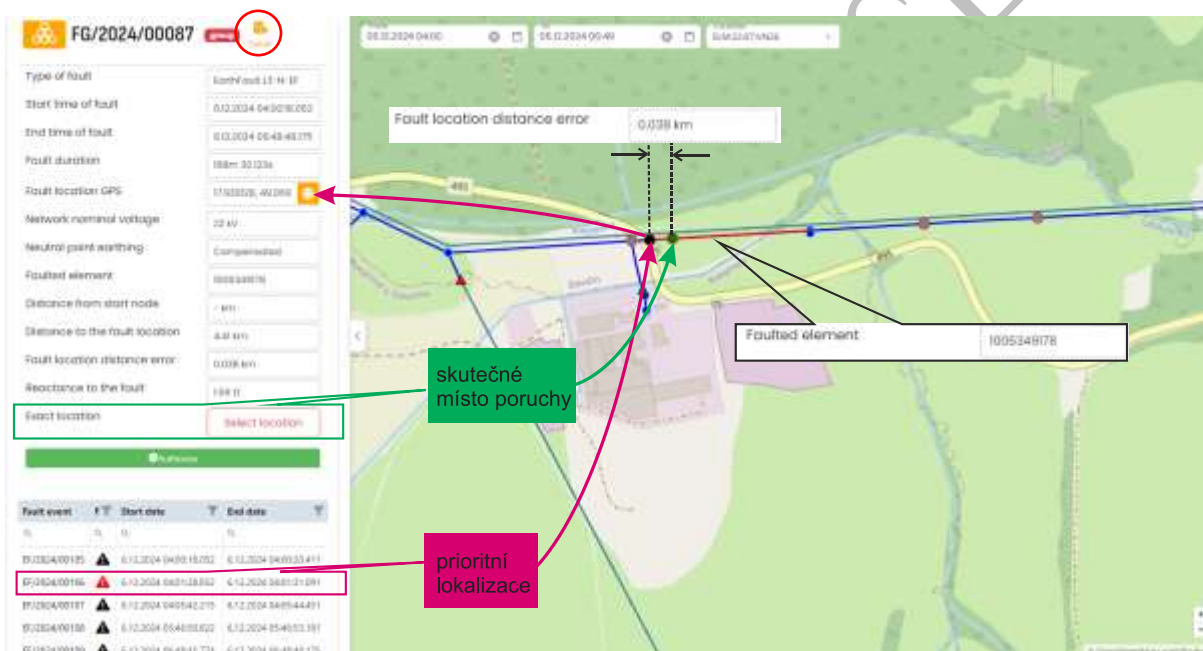

Figure 4 Display and basic description of the group of disorders

3.3.2. FAULT GROUP DETAIL INFORMATION

The FG Detail Information Panel is divided into two sections. In the first one, there is a detailed description of the group of failures through items that are identical to the detailed description of the failure event and their meaning is given in Table 2 with the exceptions listed in the previous chapter.

The last step is to save it (**Save**) and authorisation (**Save and Authorize**) using the buttons at the bottom right (see Figure 5), where by authorizing a failure, the error message created in this way is locked for further editing, as well as the entire group of failure events. After authorization, all information about the failure and group of failures is taken as verified, e.g. for the purposes of statistics in other modules of the FRA system.

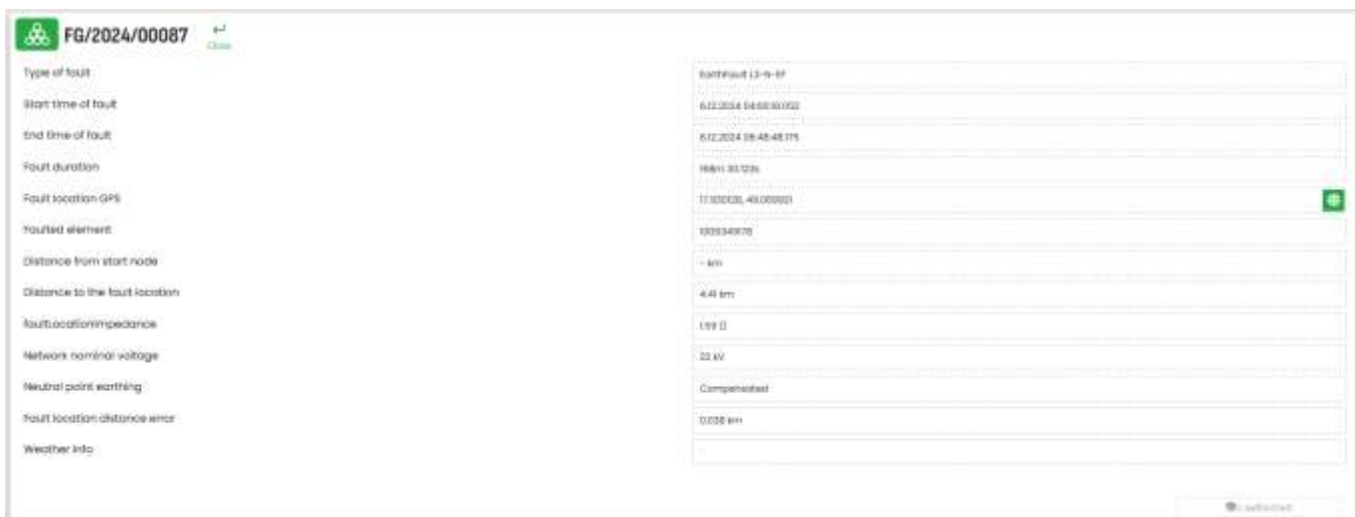

Figure 5 Part of the panel of detailed information about the group of failures

3.4. NETWORK MAP ICON DESCRIPTION

The map base for displaying fault events is equipped with a filter for filtering, located in the upper left corner - Figure 6. Failure events can be selected using this filter according to the location – by selecting the line outlet in the power substation – or by the time interval (From –To) in which the fault event was recorded. Type text in the Location field to find the name you need.

The display of the fault event is the place marked with a black dot where the fault was located and a red colour of the network element in which the fault is located – see Figure 6. The fault event is displayed in the state (configuration) of the fault terminal, which corresponds to the time of its occurrence and is given by the state of the individual switching elements (breakdown points) in the outlet at the beginning of the fault event (the outlet separation is deep blue). Switching elements are represented in the map by triangular markers and their current state is given by its coloring – green = on, red = off. Hovering over a marker displays the identifier of a specific switching element. Example of a switching element identifier in Figure 6 is the identifier of the power switch in the outlet of the VN26 power substation.

The entire outlet in the current connection is highlighted in a rich blue color in the network map (available system model) and is divided into individual sections defined by blue dots of the same color. These points also have their identification markings, which are displayed by hovering. Example in Figure 6 shows the endpoint identifier of the network element with the TS designation that corresponds to the distribution transformer station (DTS).

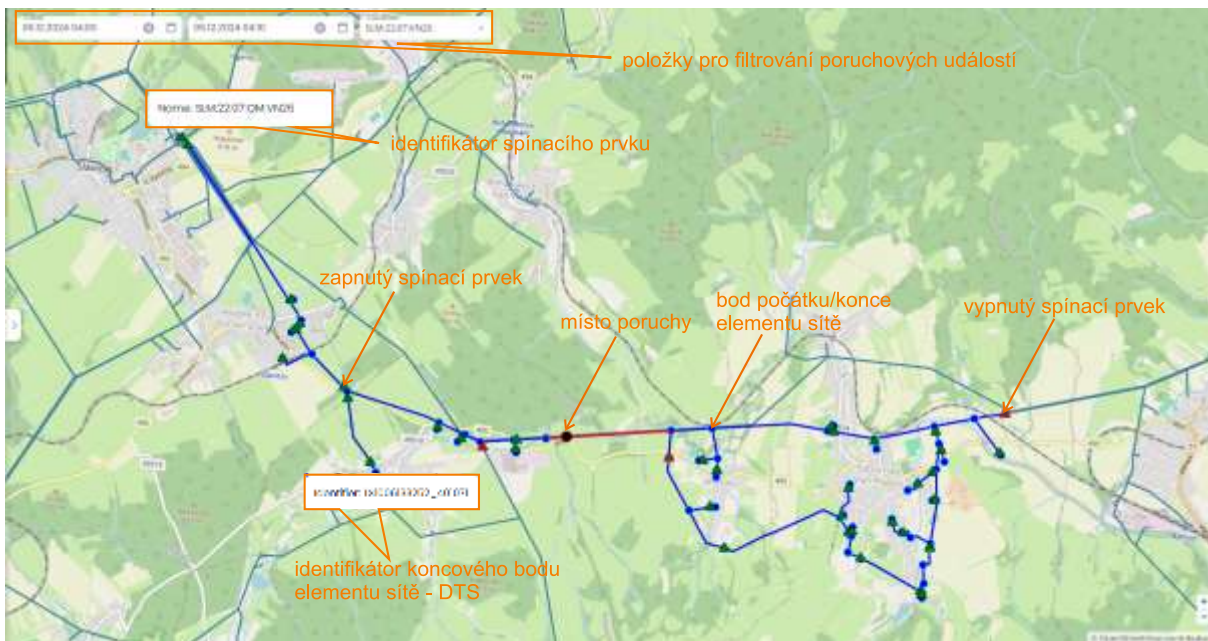

Figure 6 – Legend of the map base

4. VQI MODULE USER INTERFACE

Currently, the voltage quality (VQ) is evaluated as a binary value. It either fully complies or does not comply with the ČSN EN 50160 standard and other relevant standards for the given moment and place of measurement. The introduction of a continuous function to evaluate how close each parameter (voltage, frequency, unbalance, etc.) is to acceptable compatibility limits, combined with some aggregation techniques for each measurement point, can provide the distribution system operator with a rich and meaningful voltage quality index (VQI). This individual index for the measurement point can then be aggregated again to create a global index for a specific area of interest, and the evolution of the VQ over time can be used for dispatch control, planning or network development.

The aim of this module is to interpret the characteristic voltage parameters using the voltage quality index (VQI) with values of 1 to -1, which will allow for a more detailed assessment of the state of voltage quality in the monitored area, whereby:

- a) $VQI = 1$ indicates the ideal voltage quality parameters in a given aggregation interval
- b) $1 > VQI > 0$ indicates deteriorated voltage quality parameters in a given aggregation interval
- c) $VQI = 0$ indicates the voltage quality parameters at the limit of their limits for a given aggregation interval
- c) $0 > VQI > -1$ indicates voltage quality parameters below their defined limits

The source data provided by the Power Quality Analyzer forms matrix a) in the figure below. This three-dimensional matrix contains the measured data of individual characteristic parameters, see the "Index" axis (denoted by the index i), for individual nodes see the "Location" axis (denoted by the index l) with a reading interval (by default 10 minutes – see source data), the "Time" axis (denoted by the index t).



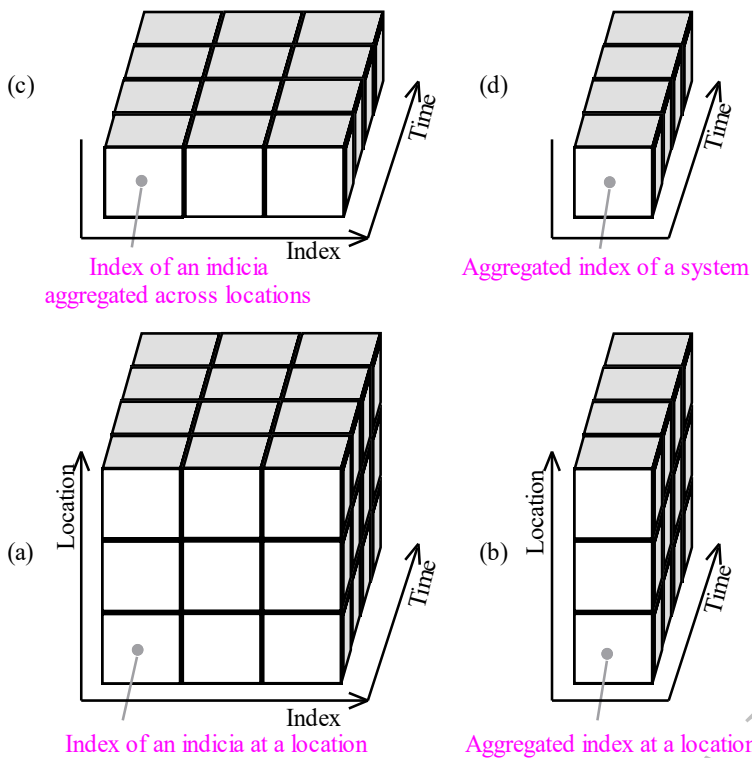

Giant. 2: Aggregation of data provided by power quality analyzers

VQI aggregation within the module is performed at three levels:

- a) time (aggregation to selected intervals of 10 minutes, 1 hour, 24 hours, etc.)
- b) the assessed area (the monitored area is aggregated into one global VQI, e.g. aggregation per HV pin, which is performed on the basis of data from all monitors available on this pin)
- c) across quality parameters/indices (aggregation of all parameters into one global VQIall)

4.1. VQI MODULE MAIN CARD

The VQI module card consists of three basic parts:

- a) Settings (allows you to set and load the VQI index)
- b) Map base (visualizes the filtered area and measurement locations of VQI source data in this area)
- c) Tables and graphs for visualizing VQI results



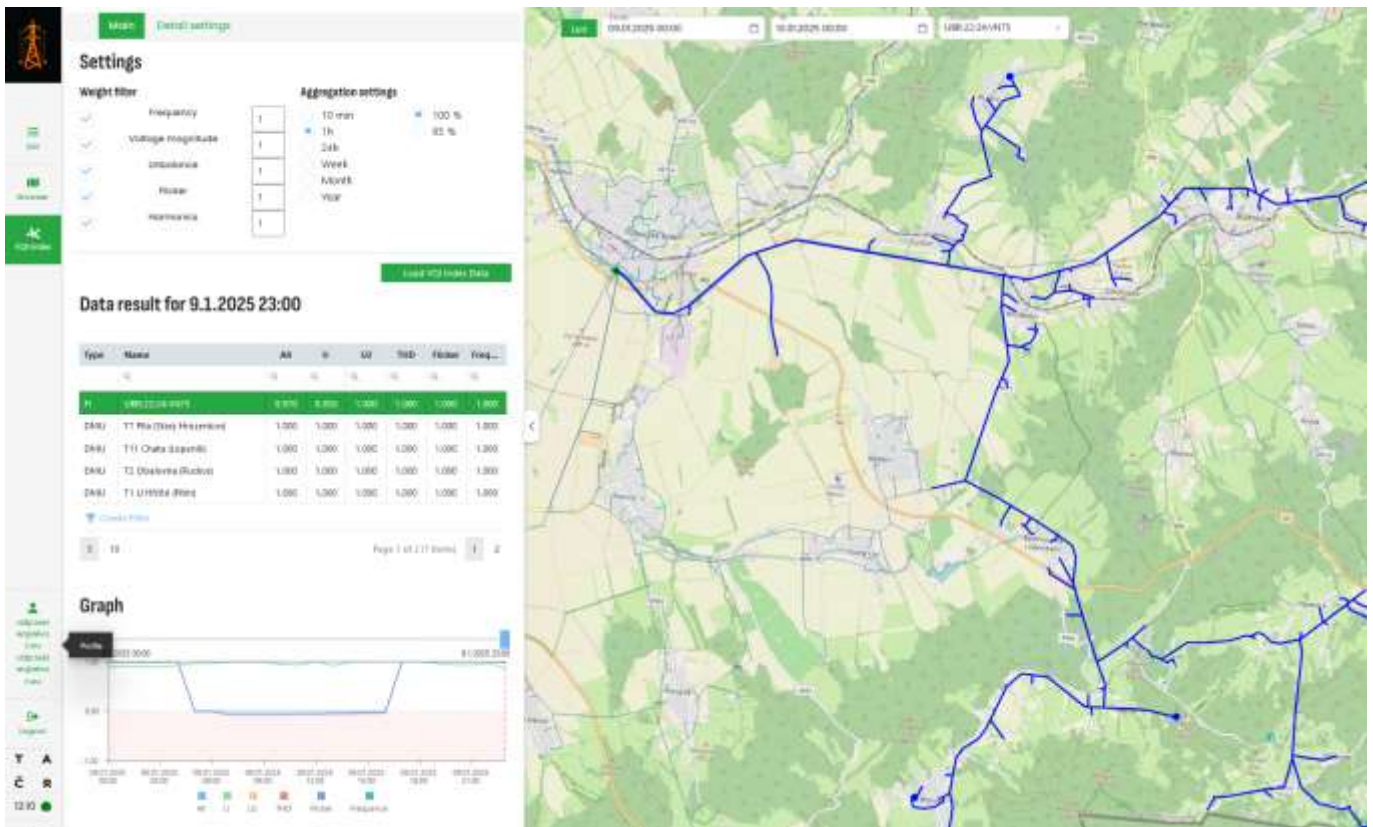

Giant. 3: VQI Module User Interface

4.1.1. SETTING

The card allows you to set aggregation rules for calculating the VQI index (VQI All) over all the desired parameters of voltage, frequency, voltage level, unbalance, flicker and harmonic distortion. The VQI index is loaded and calculated only on the basis of the parameters that are checked on this card (checkboxes in the card for each frequency parameter, voltage level, unbalance, flicker and harmonic distortion).

Setting the weight of individual voltage parameters for VQI calculation:

Based on the weight of individual parameters, which is equal to 1 in the basic settings, it is possible to adjust the influence (importance) of individual parameters on the resulting VQI All index. These weights can be set between 1 and 0 for each parameter, multiplying the VQI sub-indices (setting the weight to 0 disqualifies this parameter when calculating VQI).



To set the size of the aggregation window:

The source data provided by the quality analyzers has a granularity of 10 minutes (it is sent at 10-minute intervals). Within the *Aggregation setting*, it is possible to choose a larger aggregation interval: 1h, 24h, week, month. As part of the input data reading and calculation of the VQI index, aggregation is performed to the selected interval, which reduces the resolution of individual VQI indices over time.

Filtering extremes in aggregation intervals:

If a larger aggregation interval than the basic 10 minutes is selected, it is possible to choose 100% or 95% representation of values for aggregation, where in the case of 95% of the setting, 5% of the largest values within the given aggregate are excluded from the calculation of the VQI index.

4.1.2. DETAIL SETTINGS

Here it is possible to configure the Ksi weighing function for the resulting calculation of the VQI index. To do this, it is necessary to set the nominal values and limits of the characteristic voltage parameters:

a) Nominal value of frequency and LV phase voltage (other parameters do not have a prescribed nominal value).

b) Limits of characteristic parameters of frequency (Power frequency), voltage level (Voltage magnitude), voltage unbalance (Voltage unbalance), harmonic distortion of voltage (THD), voltage flicker (Flicker), resulting from national or international voltage quality standards for the given area.

Load default values – allows you to load the basic settings of all parameters in the tab.

The screenshot shows a web interface for configuring voltage quality parameters. It features a 'Main' tab and a 'Detail settings' tab. The 'Voltage quality parameter' section includes a 'Load default values' button. Below this, there are five parameter groups, each with a table of settings:

Parameter	Nominal	Max/Min	Z _{jp+}	Z _{jp-}	Limit
Power frequency	50 Hz	2 Hz -3 Hz	0.70	-0.70	100 %
Voltage magnitude	230 V	230 V -230 V	0.60	-0.60	10.00 %
Voltage unbalance	0	10 %	0.70	-	2 %
THD	0	30 %	0.70	0	8 %
Flicker	0	10	0.70	0	1 %

It is also possible to set the extremes (maximums and minimums) of individual parameters (Max/Min), these levels define the value of $VQI = -1$ and the area for assessing the ideal state of the monitored quality parameters, where $VQI = 1$, adjustable using the parameters Z_{jp+} and Z_{jp-} .

An example of the effect of the above setting for the voltage level on the corresponding appraisal function (Ksi) is shown in the figure below for the setting: ξ_i

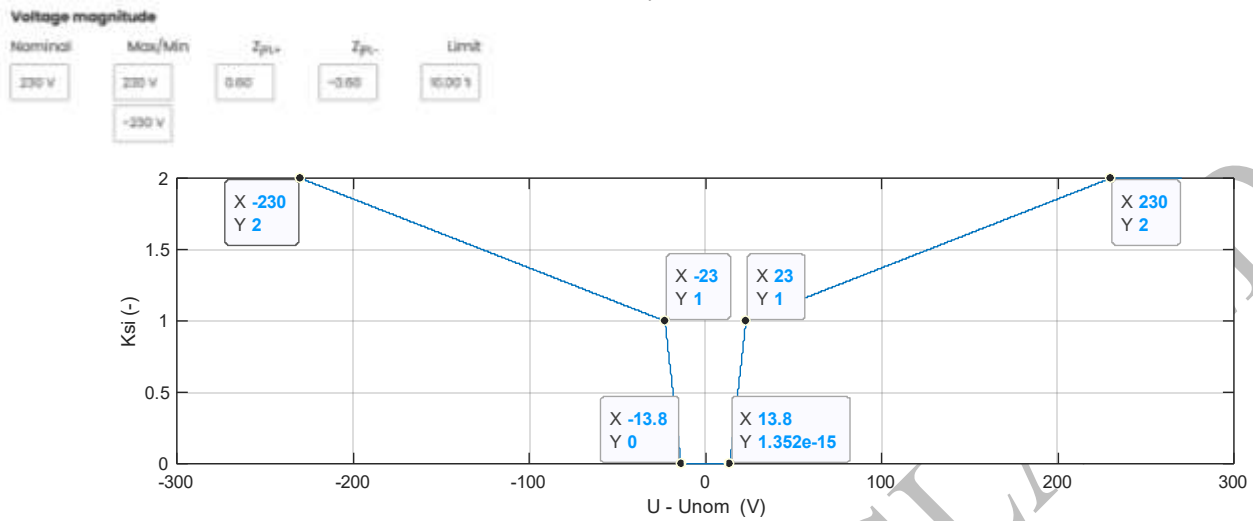

Giant. 4: Ksi appreciative function for voltage deviation

The range $Ksi = 0$ is given by the limit $\pm 10\%Unom$ and the values of Z_{jp+} and Z_{jp-} , i.e. the negative limit is given as $230V \cdot 0.1 \cdot -0.6 = -13.8V$ and $13.8V$ positive.

The value of $Ksi = 1$ is given by the limit of $\pm 10\%Unom$, i.e. $\pm 23V$.

The value of $Ksi = 2$ is given by the called Max (230V) and Min (-230V) limits.

VQI Index Calculation

Calculated for each sample of time increment t , characteristic parameters i , for each phase p , for each site (DMU) l , Obtained for three-phase parameters by multiplying the weights of each parameter, filtered by index ξ_s .

$$VQI_i^{(t,l,i,s,p)} = 1 - (\mu_i \cdot \xi_i^{(t,l,i,s,p)}), \quad (4.1.2.1)$$

where:

- μ_i – selected weight of the parameter
- $\xi_i^{(t,l,i,s)}$ = valuation function, which can take values from 0 to 2; if it is greater than one, it expresses the degree of exceeding the maximum permissible value of the deviation.

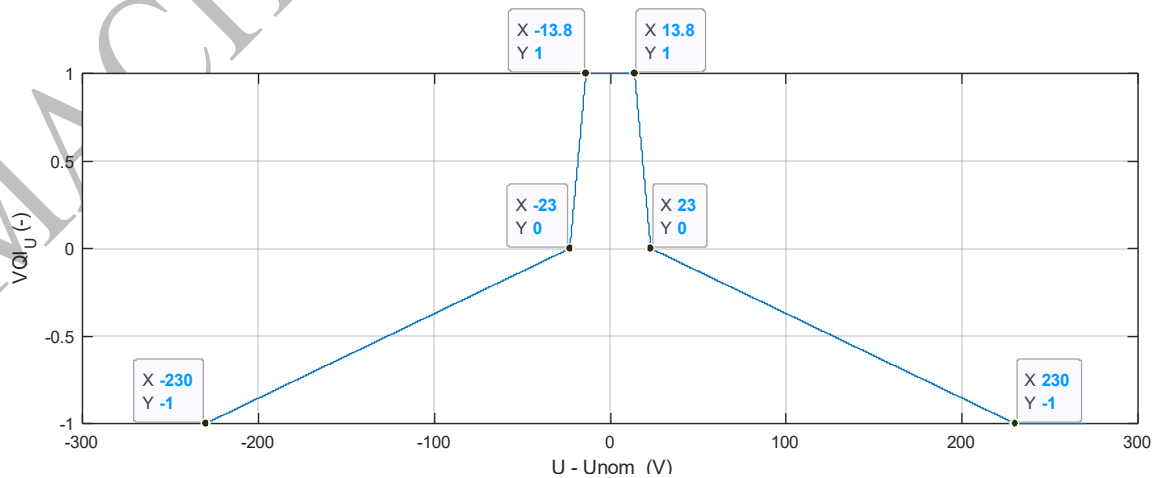

Giant. 5: VQI value for voltage deviation (for parameter weight = 1)



4.2. RETRIEVE VQI DATA

To set the aggregation rules in the Settings section, it is possible to load the data for the calculation of VQI indices based on the fields highlighted in yellow in the image below:

- From / To* – the start/end date of the source data for the calculation of the VQI index
- Location* – defining the relevant HV pin for VQI calculation – only source data from monitors located on this pin will be analyzed (normal pin connection is considered)
- Load VQI Index Data* – after filtering the source data, you can start calculating VQI indexes using this button.

Settings

Weight filter

- Frequency: 1
- Voltage magnitude: 1
- Unbalance: 1
- Flicker: 1
- Harmonics: 1

Aggregation settings

- 10 min: 100 %
- 1h: 95 %
- 24h
- Week
- Month
- Year

Data result for 11.1.2025 23:00

Type	Name	All	U	U2	THD	Flicker	Freq...
FI	UBR22234-VN75	0.999	0.946	1.000	1.000	1.000	1.000
DMU	T3 POLICE (Březová)	0.972	0.889	1.000	1.000	1.000	1.000
DMU	T7 Rla (Starý Hrozenkov)	1.000	1.000	1.000	1.000	1.000	1.000
DMU	T11 Chata (Lopeník)	1.000	1.000	1.000	1.000	1.000	1.000
DMU	T2 Obakova (Rudice)	1.000	1.000	1.000	1.000	1.000	1.000

4.2.1. TABLES AND GRAPHS WITH VQI RESULTS

After filtering and loading the input data, a list of all locations for which the VQI index is known is displayed in the table below. The breakdown is made according to the type of node: *DMU* – VQI at the location of the voltage monitor (LV voltage monitor located on the secondary side of the HV/LV transformer), *FI* – VQI corresponding to the outlet protection location (this index is calculated based on the aggregation of data from all DMUs located on this outlet for normal display) – if only one outlet is filtered, this is Normal view rendered in the map base.

For example, below is a table with a list of all available VQI locations for the time slice displayed in the table header (after loading, the time of the last available aggregate - Last is given by default) and its individual values for:

- Name* – name of the node for which the VQI index has been calculated (i.e. the name of the distribution transformer station or outlet protection/HV outlet)



- b) *All* – VQI aggregating indices of all characteristic parameters, i.e. Power frequency, voltage magnitude, Voltage unbalance, Voltage Harmonic Distortion (THD), Voltage Flicker
- c) *U* – VQI presenting only the voltage level (Voltage magnitude)
- d) *U2* – VQI presenting only Voltage unbalance
- e) *THD* – VQI presenting only the total harmonic distortion of the voltage (THD)
- f) *Flicker* – VQI presenting only flicker (flicker)
- g) *Frequency* - VQI presenting only the frequency (Power frequency)

In the table, negative VQIs (characteristic parameters exceed defined limits) are highlighted in red.

Data result for 11.1.2025 23:00

Type	Name	All	U	U2	THD	Flicker	Freq...
FI	UBR:22:24:VN75	0.989	0.946	1.000	1.000	1.000	1.000
DMU	T3 POLICIE (Březová)	0.972	0.869	1.000	1.000	1.000	1.000
DMU	T7 Pila (Starý Hrozenkov)	1.000	1.000	1.000	1.000	1.000	1.000
DMU	T11 Chata (Lopeník)	1.000	1.000	1.000	1.000	1.000	1.000
DMU	T2 Obalovna (Rudice)	1.000	1.000	1.000	1.000	1.000	1.000

Create Filter

5 10

Page 1 of 2 (7 items) 1 2

Note: Within the table, it is possible to use sorting or filtering based on any header parameter.

Below the table, a graph is displayed showing the time courses of the VQI index for the selected place in the table (FI or DMU) – highlighted in green (in this case UBR:22:24:VN75). Using the slider, it is possible to select the reference time for which the values in the table will be updated (see the image below). In this image, you can then activate or deactivate individual VQI (colored icons of individual parameters at the bottom of the chart).

Graph



The last graph in the left part of the panel is intended for a more detailed analysis and mutual comparison of individual places (areas) based on the selected parameter (*All, U, U2, THD, Flicker, Frequency*). In this graph, you can select the places (DTS or pins) that will be inserted into the graph in the first menu, and based on the icons at the bottom, you can then hide the selected waveforms of the VQI indices.

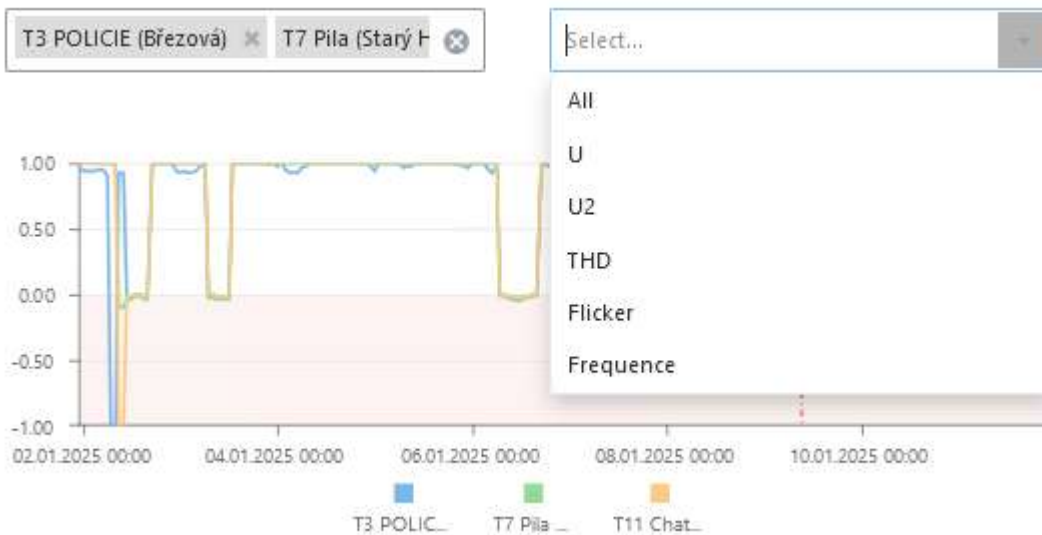

4.2.2. VQI MAP BASE

After filtering and loading the input data, the map base displays the relevant area of the HV line (deep blue) and displays the individual evaluated points, i.e. the measurement locations (DTS and the beginnings of the HV outlets). In this map base, the current VQI time section is plotted (the time of this section is located above the table), where in the map base the VQI places are colored green or red according to the VQI level (the places where VQI < 0 are displayed in red).

Note: By pointing the cursor to the appropriate measurement location, more detailed information about that location will be displayed with the current VQI All value.

